



1 PIECE BALL VALVE PN40



WSF
ISO9001

TÜVRheinland®
PED/2014/68/EU



Certificate 3.1

Size : DN 1/4" to 2"
Ends : Threaded BSP
Min Temperature : -20°C
Max Temperature : + 180°C
Max Pressure : 40 Bars
Specifications : Anti blow-out stem
Locking device
1 piece type

Materials : Stainless steel ASTM A351 CF8M



1 PIECE BALL VALVE PN40

SPECIFICATIONS :

- Reduced bore
- Anti blow-out stem
- Locking device
- Solid ball
- 1 piece type

USE :

- Chemical and pharmaceutical industries, petrochemical industries, hydraulic installation, compressed air
- Min and max Temperature Ts : -20°C to + 180°C
- Max Pressure Ps : 40 bars (see graph)

PRESSURE / TEMPERATURE GRAPH (STEAM EXCLUDED) :

PRESSURE

BAR

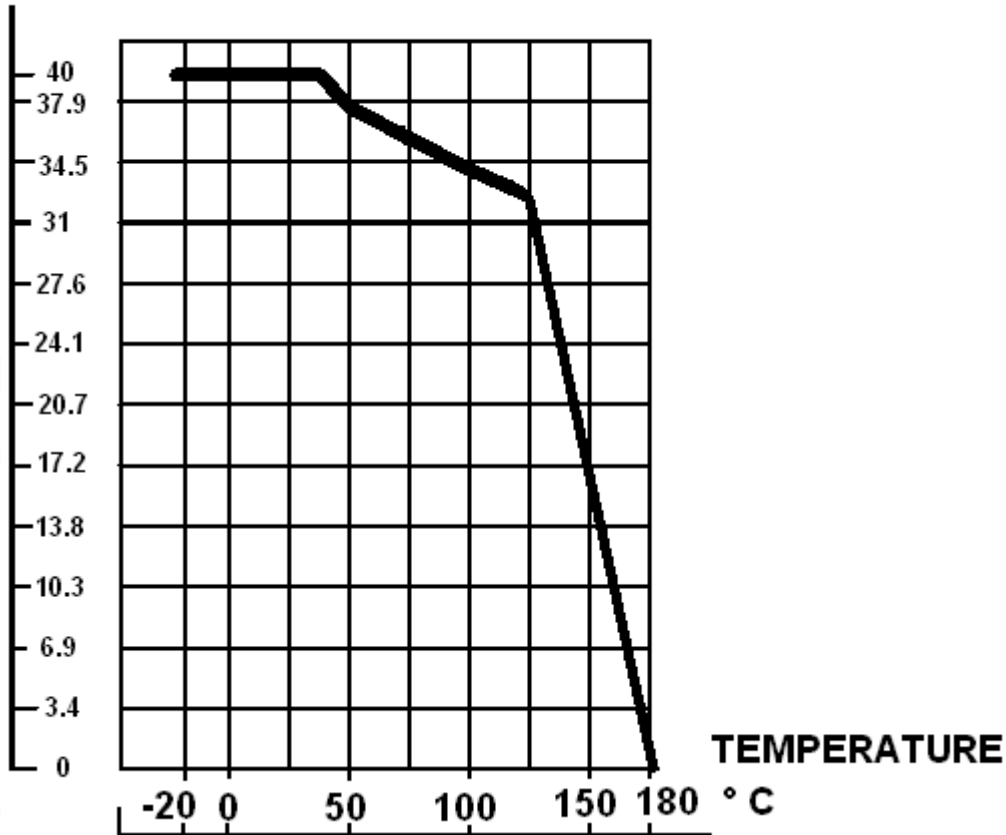

1 PIECE BALL VALVE PN40

RANGE :

- Stainless steel DN 1/4" to DN 2"

ENDS :

- Female / female threaded BSP

MATERIALS :

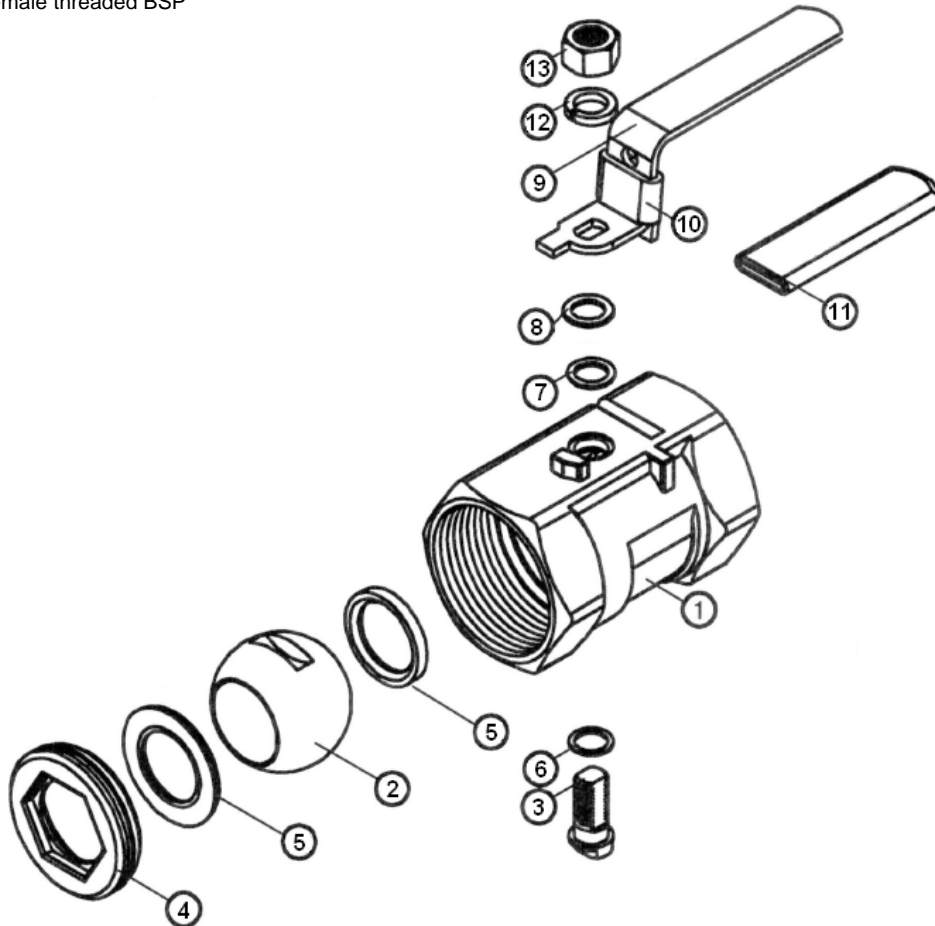

| Item | Designation | Materials |
|------|----------------|----------------|
| 1 | Body | ASTM A351 CF8M |
| 2 | Ball | ASTM A351 CF8M |
| 3 | Stem | AISI 316 |
| 4 | Insert | |
| 5 | Seat | PTFE |
| 6 | Stem packing | PTFE |
| 7 | Thrust washer | PTFE |
| 8 | Gland | AISI 304 |
| 9 | Handle | |
| 10 | Locking device | |
| 11 | Handle cover | |
| 12 | Handle washer | AISI 304 |
| 13 | Handle nut | |

1 PIECE BALL VALVE PN40

SIZE (in mm) :

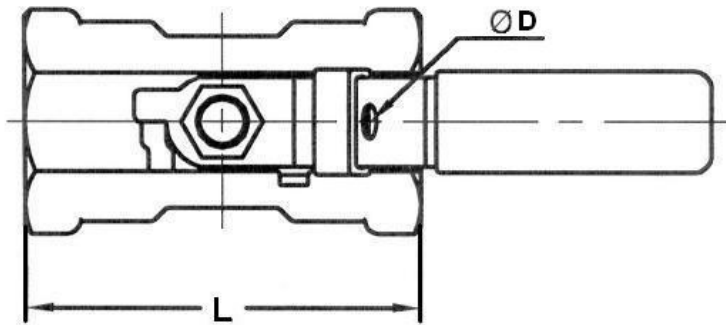

Stem size :

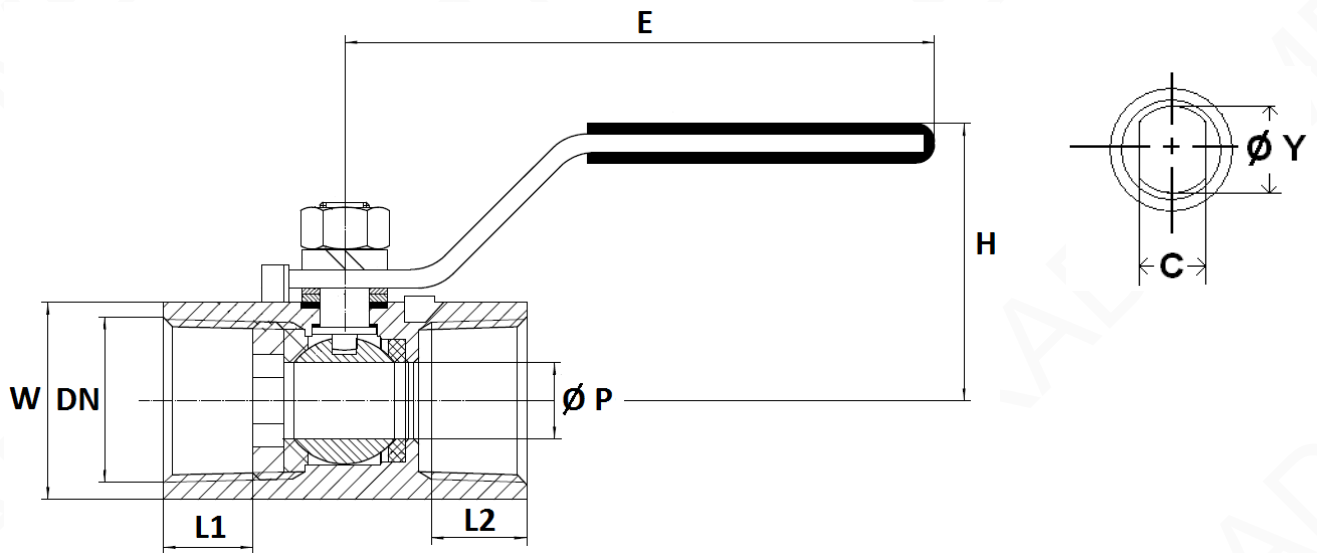

| Ref. | DN | 1/4" | 3/8" | 1/2" | 3/4" | 1" | 1"1/4" | 1"1/2" | 2" |
|-------------|-----------|------|------|------|------|------|--------|--------|------|
| 708 | Ø P | 5 | 6.8 | 9 | 12.5 | 16 | 20 | 25 | 32 |
| | L | 39 | 44 | 56.5 | 58.5 | 71 | 78 | 83 | 100 |
| | Ø D | 6 | 6 | 8 | 8 | 8 | 8 | 8 | 8 |
| | E | 65 | 65 | 96 | 96 | 101 | 101 | 135 | 135 |
| | H | 32 | 35 | 45 | 48 | 56 | 61 | 70 | 76 |
| | L1 | 9.5 | 10.5 | 16 | 15 | 17 | 19 | 20 | 23 |
| | L2 | 9.5 | 10.5 | 14 | 15 | 17 | 19 | 19 | 23 |
| | W on flat | 17 | 21 | 25 | 32 | 38 | 48 | 53 | 66 |
| | C | 3 | 4 | 5 | 5 | 6 | 6 | 8 | 8 |
| | Ø Y | 4,6 | 6 | 7 | 7 | 9 | 9 | 11.5 | 11.5 |
| Weight (Kg) | 0.06 | 0.1 | 0.19 | 0.26 | 0.41 | 0.62 | 0.84 | 1.33 | |



1 PIECE BALL VALVE PN40

FLOW COEFFICIENTT Kvs (M3 / h) :

| DN | 1/2" | 3/4" | 1" | 1"1/4 | 1"1/2 | 2" |
|--------------|------|------|----|-------|-------|-----|
| Kvs (m3/h) | 9 | 19 | 45 | 80 | 125 | 165 |

TORQUE VALUES (in Nm without safety coefficient) :

| DN | 1/4" | 3/8" | 1/2" | 3/4" | 1" | 1"1/4 | 1"1/2 | 2" |
|-------------|------|------|------|------|----|-------|-------|----|
| Torque (Nm) | 2 | 2 | 3 | 4 | 5 | 6 | 8 | 10 |

STANDARDS :

- Fabrication according to ISO 9001 : 2015
- DIRECTIVE 2014/68/EU : CE N° 0035
Risk Category III Module H
- Certificate 3.1 on request
- Pressure tests according to ISO 5208, Rate A
- Threaded cylindrical BSP ends according to ISO 228-1

ADVICE : Our opinion and our advice are not guaranteed and MXT shall not be liable for the consequences of damages.
The customer must check the right choice of the products with the real service conditions.



1 PIECE BALL VALVE PN40

INSTALLATION AND MAINTENANCE

BEFORE INSTALLATION :

Pipe-line must be cleaned and free from residual of weldings, rubbish, shaving and every kind of extraneous materials. Pipe-line must be perfectly aligned and their support properly dimensioned so that there's no external constraint.

Please use the right product according to the services conditions to seal the valve.
Use the right bolt tightening so that the ends won't be damaged.

CLEANING AND TESTS

Keep opened the valves during the cleaning operation so that there are no impurities between the ball and the body.

Tests under pressure must be done with a cleaned pipe-line.

Open partially the valve for tests. Pressure test do not exceed the valve specifications according to EN 12266-1.

MAINTENANCE

It's recommended to operate the valve twice (open and close) 1 to 2 times per year.

When intervention on the valve, be sure there's no pressure in the pipe-line, there's no fluid in it, and that it is isolated.

The temperature must be low enough to operate without risks.

If there's a corrosive fluid, inert installation before intervention.

When the valve is under pressure :

If there's a leakage at the packing, tighten it slightly so that the leakage disappears.